

Model: **DGC-1375**

Powered by CUMMINS



DIESEL GENERATING SET 400/230V-50Hz-3Phase

PERFORMANCE DATA:

Model Rated	DGC-1375	
Alternator Brand:	STAMFORD	S6L1D-G41
Diesel Engine Brand:	CUMMINS	KTA50-G3
Power (ESP)	KVA/KW	1345/1076
Power (PRP)	KVA/KW	1250/1000
Phases		3
Starter Voltage	V	24
Rated Current	A	1942
Rated rotation speed	r/min	1500
Power Factor		0.8
Fuel Consumption	Liter/hour	261L/h
Fuel Tank Capacity	Liter	Open Type: /
		Silent Type: -
Noise level	dB(A)@7m	Silent Type: 87±2

Prime Power (PRP):

According to ISO 8528-1:2018, Prime power is the maximum power which a generating set is capable of delivering continuously whilst supplying a variable electrical load when operated for an unlimited number of hours per year under the agreed operating conditions with the maintenance intervals and procedures being carried out as prescribed by the manufacturer. The permissible average power output (Ppp) over 24 h of operation shall not exceed 70 % of the PRP

Emergency Standby Power (ESP):

According to ISO 8528-1:2018, Emergency standby power is the maximum power available during a variable electrical power sequence, under the stated operating conditions, for which a generating set is capable of delivering in the event of a utility power outage or under test conditions for up to 200 h of operation per year with the maintenance intervals and procedures being carried out as prescribed by the manufacturers. The permissible average power output over 24 h of operation shall not exceed 70 % of the ESP.



Duragen Company with quality certification ISO 9001 and only Stamford's authorized distributor in Thailand

STANDARDS:

Generator Set: GB/T2820—2009, ISO8528

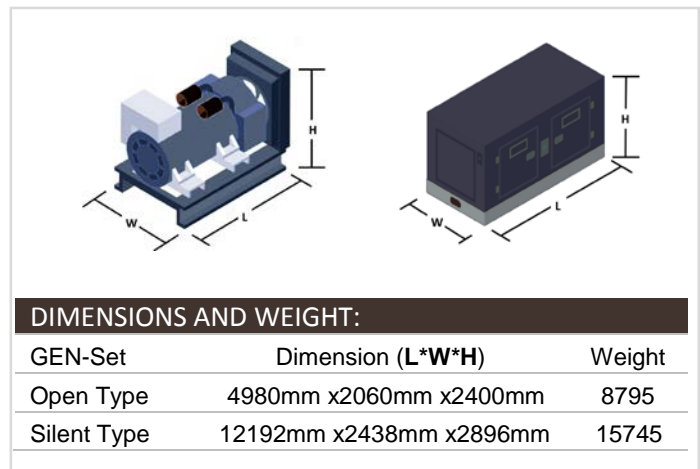

DIMENSIONS AND WEIGHT:

GEN-Set	Dimension (L*W*H)	Weight
Open Type	4980mm x2060mm x2400mm	8795
Silent Type	12192mm x2438mm x2896mm	15745

CONFIGURATION:

Standard: Engine, alternator, cooling system, Base frame (excluding fuel tank), shock absorber, air inlet system, control box (including mains floating charge), plastic fan blades (when the engine and water tank do not bring).

Optional: Base frame (including fuel tank), water jacket heater, fuel water separator, fuel heater, fuel level sensor (only supporting under frame tank), switch box (with switch), power switch, the water level sensor, motor anti condensation heater, automatic fueling system (only supporting base frame including fuel tank), battery frame.

Accessories: Silencer, bellow, exhaust silencing system accessories (with the matching engine), regular battery, starting cord assembly, data of gen-set, random tool (with the matching engine)

ENGINE SPECIFICATION: CUMMINS

Model	KTA50-G3
Engine speed Rated	1500 RPM
Cylinder /Arrangement	16/60
Displacement	50.3 L
Bore and Stroke	159mm×159mm
Compression ratio	13.9:1
Max. stand by power at rated RPM	1227 KW
Frequency regulation, steady state	≤0.25%
Governor: type	Electrical
Aspiration and Cooling	Turbocharged & After cooler
Exhaust System	
Exhaust gas flow	4529Kg/min
Exhaust temperature	585°C
Max back pressure	10kPa

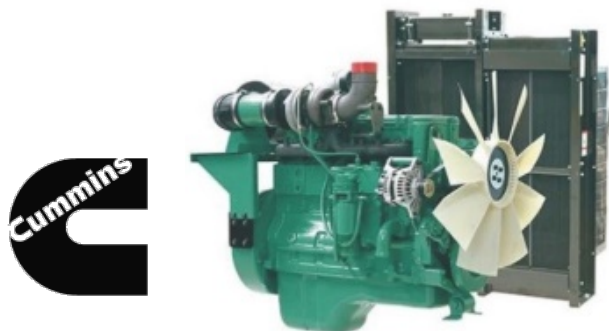

ALTERNATOR SPECIFICATION: STAMFORD

Type	S6L1D-G41
Number of phase power	3
Factor (Cos Phi)	0.8
Pole	4
Bearing	1
Coupling	Direct
Exciter type	PMG Excited
Insulation: Class, Temperature rise	H / H
Degree of protection	IP23
AVR model	MX341
Altitude	≤1000m
Winding Pitch	2/3
Winding Leads	6/12

Fuel System

Fuel consumption 100% (of the Prime Power)	261 L/h
Fuel consumption 75% (of the Prime Power)	/ L/h
Fuel consumption 50% (of the Prime Power)	/ L/h
Fuel consumption 25% (of the Prime Power)	/ L/h

Oil System

Total oil capacity w/filters	177.0 L
------------------------------	---------

Air intake

Engine air flow	1643 L/s
-----------------	----------

Coolant System

Radiator & engine capacity	134 L
Max water temperature	104 °C
Thermostat	82-93°C

- Cummins engines with advanced design, reliable performance, durable operation
- Alloy-steel and connecting steel-lever, high durability
- High combustion efficiency and low fuel consumption, work continuously
- P/T pump injection technology, low cost, completely combustion

STANDARDS

- BS-5514, DIN-6271, ISO-3046

Note: All data sheets for reference only and subject to change without prior notice

FEATURES

- Utilizing wire-wound* (random-wound) technology
- Environment alternators are the industrial benchmark for all generator set configurations.
- Brushless excitation with AVR
- IP21, IP22, IP23, IP44 enclosure protection,
- The ideal solution for marine/offshore, UPS, telecoms, basic and advanced protection, construction and other continuous or standby power applications.

STANDARDS

- GB755, BSEN60034, BS5000-3, VDE0530, IEC34, CSAC22.2-10, BSENISO9001, IB100, AS1359, IEC 60034-1, NEMA MG-1 22, 32 & 33, ISO 8528-3, EN 61000-6-2 and 6-4
- All alternators are manufactures in IOS 9001 and ISO 14001 environments.



STAMFORD | AvK™

CONTROL PANEL

MODEL:	DSE 7320 AUTO START & AUTO MAINS FAILURE CONTROL MODULES
DIMENSION	OVERALL 240mm x 181mm x 42mm (9.4" x 7.1" x 1.6")
PANEL CUT-OUT	220mm x 160mm (8.7" x 6.3")
WEIGHT	400g (0.4kg)



KEY FEATURES

- 4-Line back-lit LCD text display
- Five key menu navigation
- Front panel editing with PIN protection
- Customizable status screens
- Power save mode
- Support for up to three remote display units
- 9 configurable inputs
- 8 configurable outputs
- Flexible sender inputs
- Configurable timers and alarms
- 3 configurable maintenance alarms
- Multiple date and time scheduler
- Configurable event log (250)
- Tier 4 CAN engine support
- Advanced SMS messaging (additional external modem required)
- Start & stop capability via SMS messaging
- Additional display screens to help with modem diagnostics
- Idle control for starting & stopping.
- DSENet® expansion compatible
- Integral PLC editor
- Easy access diagnostic page
- CAN and Magnetic Pick-up/Alt. sensing
- Fuel usage monitor and low fuel alarms
- Charge alternator failure alarm
- Manual speed control (on compatible CAN engines)
- Manual fuel pump control
- Engine exerciser
- "Protections disabled" feature
- kW & kV Ar protection
- Reverse power (kW & kV Ar) protection

- LED and LCD alarm indication
- Power monitoring (kW h, kV Ar, kVAh, kVAr h)
- Load switching (load shedding and dummy load outputs)
- Automatic load transfer (DSE7320)
- Unbalanced load protection
- Independent Earth Fault trip
- True dual mutual standby with load balancing timer (DSE7310 only)
- USB connectivity
- Backed up real time clock
- Fully configurable via DSE Configuration Suite PC software
- Configurable display languages
- Remote SCADA monitoring via DSE Configuration Suite PC software
- User selectable RS232 and RS485 communications
- Configurable Gencom pages

KEY BENEFITS

- 132 x 64 pixel ratio display for clarity
- Real-time clock provides accurate event logging
- Multiple date and time scheduler
- Set maintenance periods can be configured to maintain optimum engine performance
- Ethernet communications (via DSE860/865 modules), provides advanced remote monitoring at low cost
- Modules can be integrated into building management systems(BMS)
- Increased input and output expansion capability via DSENet®
- License-free PC software
- IP65 rating (with supplied gasket) offers increased resistance to water ingress
- PLC editor allows user configurable functions to meet specific application requirements.

STANDARD CONTROL FUNCTIONS ENGINE

- Coolant Temperature
- Oil Pressure (RSI or Bar)
- Oil Temperature
- Running Time
- Engine Battery Volts
- Engine Speed
- Fuel Level

AC GENERATOR

- AC Voltage (ph-ph) and (ph-N)
- DC Voltage*
- Current (Amps)
- Frequency (Hz)
- Load (KW, KVA, KVAh, KWh, KVA h, KVAh)
- Phase Sequence

WARNING/SHUTDOWN WITH COMMON LED INDICATION OF

- Over / Under speed shutdown
- Low oil pressure warning and shutdown
- High coolant temperature
- Fail to start (Over crank) shutdown
- Over Current warning
- Over / Under voltage
- Over / Under frequency
- Low / High battery voltage
- Emergency stop
- KW Overload

